

ICEB90 - Overcenter valve

Fully balanced, pilot assisted relief with check
90 L/min (23 USgpm) • 270 bar (4000 psi)

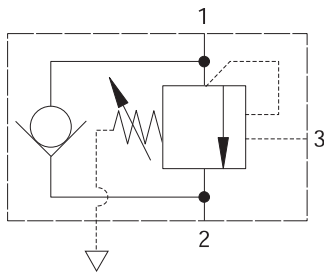

Operation

The check section allows free flow into the actuator then holds and locks the load against movement. The pilot assisted relief valve section will give controlled movement when pilot pressure is applied. The relief section is normally set to open at a pressure at least 1.3 times the maximum load induced pressure but the pressure required to open the valve and allow movement

depends on the pilot ratio of the valve. For optimization of load control and energy usage, a choice of pilot ratios is available.

The pressure required to open the valve and start actuator movement can be calculated as follows:

$$\text{Pilot Pressure} = \frac{(\text{Relief Setting}) - (\text{Load Pressure})}{\text{Pilot Ratio}}$$

Features

Cartridge is economical and fits simple cavity. Allows quick, easy field service - reduces down time. Interchangeable with pilot check valve of a similar size.

Pilot ratio

4:1 Best suited for applications where load varies and machine structure can induce instability.

Other ratios available upon request.

Sectional view

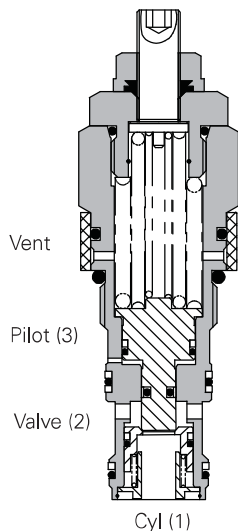

Performance data

Ratings and specifications

Performance data is typical with fluid at 32 cST (150 SUS)

Rated flow	90 L/min (23 USgpm)
Max relief pressure	350 bar (5000 psi)
Max load induced pressure	270 bar (4000 psi)
Cartridge material	Working parts steel. External surfaces zinc plated.
Standard housing materials	Aluminum up to 210 bar. Add suffix "377" for steel option.
Mounting position	Unrestricted
Cavity	A12336 (see Section M)
Torque cartridge into cavity	60 Nm (44 lbs ft)
Weight	1CEB90: .29 kg (.63 lbs) 1CEB95: 1.35 kg (2.97 lbs) 1CEB95: 2.10 kg (4.62 lbs)
Seal kit	SK634 (Nitrile) SK634V (Viton®)
Filtration	BS5540/4 Class 18/13 (25 micron nominal)
Temperature range	-30° to +90°C (-22° to +194°F)
Internal leakage	0.3 ml/min (5 dpm)
Nominal viscosity range	5 to 500 cSt

Viton is a registered trademark of E.I. DuPont.

Pressure drop

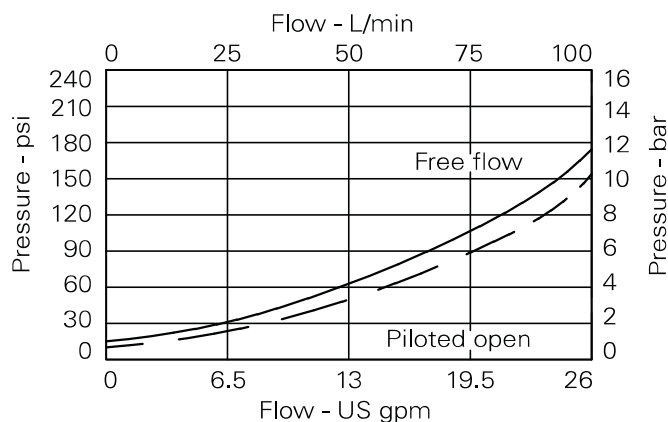

Description

Overcenter valves give static and dynamic control of loads by supplying a counterbalance pressure to the actuator. They prevent runaway in the event of hose burst and hold the load with minimal leakage.

The pressure balanced valve is unaffected by back pressure, allowing service line reliefs to operate and for the valve to be used in regenerative or proportional valve systems.

The overcenter valve should be mounted either into, onto or as close to the actuator as possible to give maximum protection.

Single overcenter valves control unidirectional loads such as in aerial platforms, cranes or winches and dual overcenters are suited to bi-directional motion such as wheel motor applications or cylinders going over center.

Where measurements are critical request certified drawings. We reserve the right to change specifications without notice.

ICEB90 - Overcenter valve

Fully balanced, pilot assisted relief with check
90 L/min (23 USgpm) • 270 bar (4000 psi)

Model code

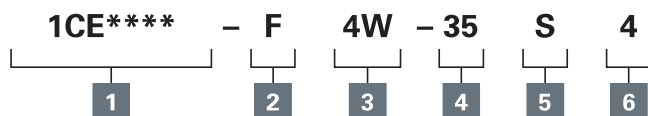

1 Function

- 1CEB90 - Cartridge only
- 1CEB95 - Cartridge and body
- 1CEEB95 - Cartridges and dual body

2 Adjustment

- F - Screw adjustment
 - N - Fixed - State pressure setting required.
- For fixed versions add setting in 10 bar increments to end of part number. Subject to a ±10% tolerance.

3 Port size

Code	Port Size	Housing number - body only			
Body Only		Aluminium single	Steel single	Aluminium dual	Steel dual
4W	1/2" BSP Valve & Cyl Port 1/4" BSP Pilot Port	B13625	B13626	C13627	C13628
8T	1/2" SAE Valve & Cyl Port 1/4" SAE Pilot Port	B10806	B10922	C10807	C11561

4 Pressure range @ 4.8 L/min

- Note: Code based on pressure in bar.
- 20 - 70-225 bar. Std setting 100 bar
 - 35 - 200-350 bar. Std setting 210 bar
- Std setting made at 4.8 L/min

5 Seal material

- S - Nitrile (For use with most industrial hydraulic oils)
- SV - Viton (For high temperature and most special fluid applications)

6 Pilot ratio

- 4 - 4:1 Other ratios available upon request

Dimensions

mm (inch)

Cartridge only Basic Code 1CEB90

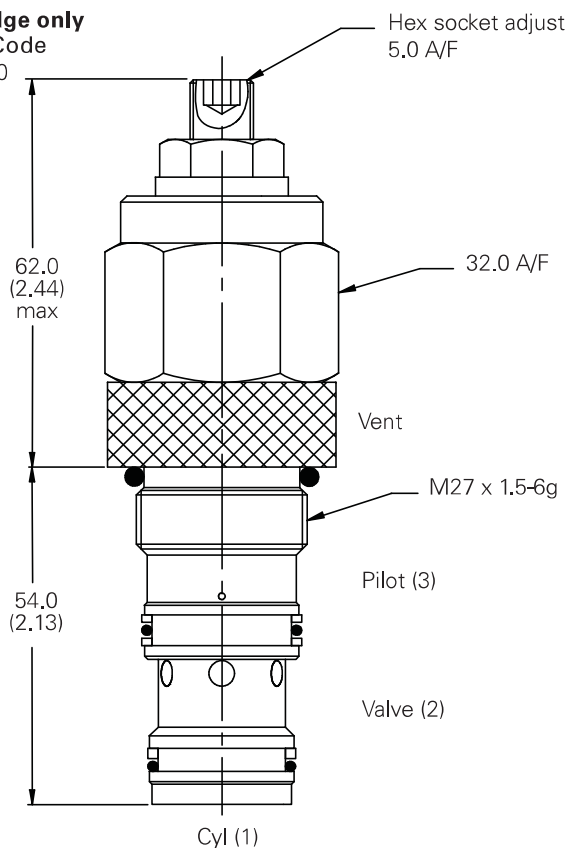

Note: Tightening torque of "F" adjuster locknut - 20 to 25 Nm.

Note: For applications above 210 bar - please consult our technical department or use the steel body option.

Single valve

1/2" Ports
Basic Code
1CEB95

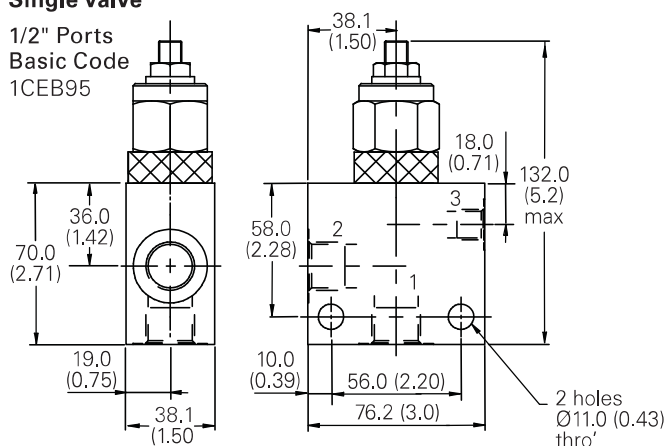

Dual valve

1/2" Ports
Basic Code 1CEEB95
Internally Cross Piloted

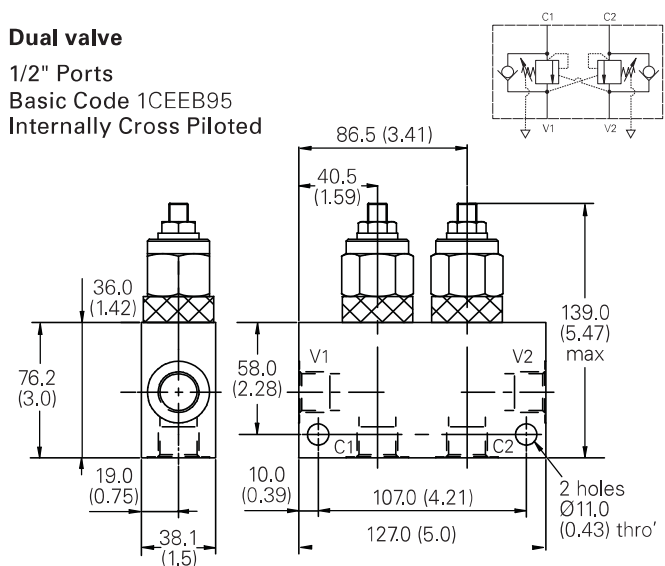

Where measurements are critical request certified drawings. We reserve the right to change specifications without notice.