

ICEBD90 - Overcenter valve

Fully balanced, pilot assisted relief with check
90 L/min (23 USgpm) • 270 bar (4000 psi)

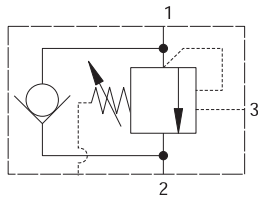

Sectional view

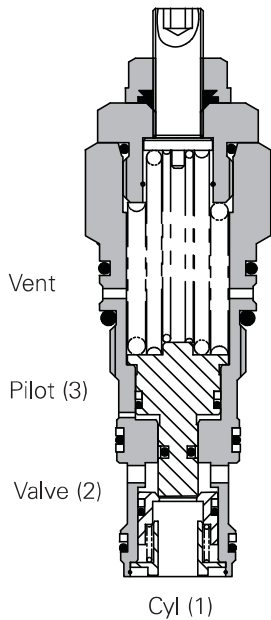

Operation

The check section allows free flow into the actuator then holds and locks the load against movement. The pilot assisted relief valve section will give controlled movement when pilot pressure is applied. The relief section is normally set to open at a pressure at least 1.3 times the maximum load induced pressure but the pressure required to open the

valve and allow movement depends on the pilot ratio of the valve. For optimization of load control and energy usage, a choice of pilot ratios is available.

The pressure required to open the valve and start actuator movement can be calculated as follows:

$$\text{Pilot Pressure} = \frac{(\text{Relief Setting}) - (\text{Load Pressure})}{\text{Pilot Ratio}}$$

Features

Cartridge is economical and fits simple cavity. Allows quick, easy field service - reduces down time.

Pilot ratio

4:1 Best suited for applications where load varies and machine structure can induce instability.

Other ratios available upon request.

Performance data

Ratings and specifications

Figures based on Oil Temp = 40°C Viscosity = 32 cSt (150 SUS)

Rated flow	90 L/min (23 USgpm)
Max relief setting	350 bar (5000 psi)
Max load induced pressure	270 bar (4000 psi)
Cartridge material	Working parts hardened and ground steel. External surfaces zinc plated.
Mounting position	Unrestricted
Cavity	A12196 (See section M)
Torque cartridge into cavity	60 Nm (44 lbs ft)
Weight	0.29 kg (0.63 lbs)
Seal kit	SK634 (Nitrile) SK634V (Viton®) SK634P (Polyurethane/Nitrile)
Filtration	BS5540/4 Class 18/13 (25 micron nominal)
Temperature range	-30° to +90°C (-22° to +194°F)
Leakage	0.3 milliliters/min (5 dpm)
Nominal viscosity range	5 to 500 cSt

Viton is a registered trademark of E.I. DuPont.

Pressure drop

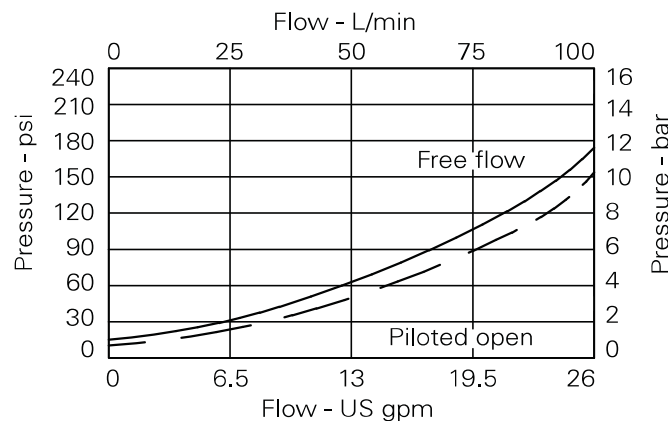

Description

Overcenter valves give static and dynamic control of loads by supplying a counterbalance pressure to the actuator. They will stop runaway in the event of hose burst and hold the load with minimal leakage.

The pressure balanced overcenter relief setting is unaffected by back pressure, enabling the valve to stay open when the valve port pressure rises. This will allow service line reliefs to work normally and will also allow the control of regenerative or proportional systems. The drain line allows the valve to be used in corrosive atmospheres preventing the ingress of atmospheric contaminant.

Single overcenter valves are normally used when the load is unidirectional, for example an aerial platform or crane and dual overcenter valves are used for controlling loads in both directional for motor applications or for cylinders going over center.

Where measurements are critical request certified drawings. We reserve the right to change specifications without notice.

ICEBD90 - Overcenter valve

Fully balanced, pilot assisted relief with check
90 L/min (23 USgpm) • 270 bar (4000 psi)

Model Code

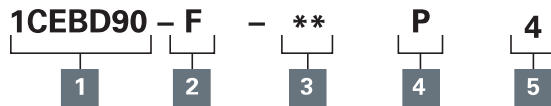

1 Function 1CEBD90

2 Adjustment means

F - Screw adjustment

3 Pressure range @ 4.8 L/min

Note: Code based on pressure in bar.

20 - 70-225 bar
Standard setting 100 bar

35 - 200-350 bar
Standard setting 210 bar

Standard setting made at 4.8 L/min

4 Seals

S - Nitrile (for use with most industrial hydraulic oils)

SV - Viton (for high temperature and most special fluid applications)

P - Polyurethane/Nitrile (for arduous applications)

5 Pilot ratio

4 - 4:1 Other ratios available upon request

Line body available on request.

Dimensions

mm (inch)

Cartridge only

Basic Code

1CEBD90

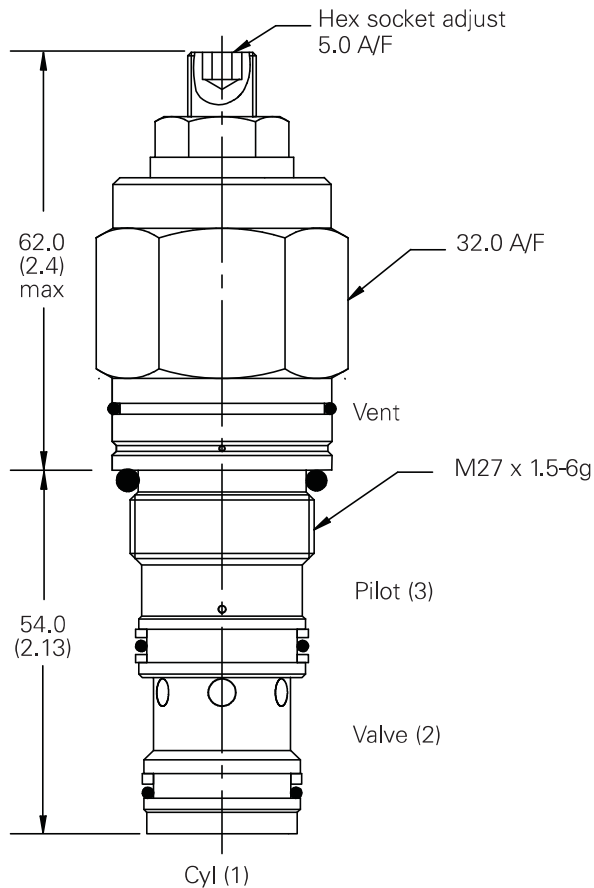

Note: Tightening torque of "F" adjuster locknut - 20 to 25 Nm

Where measurements are critical request certified drawings. We reserve the right to change specifications without notice.