

ICEESH35 - Dual overcenter valve

Pilot assisted relief with brake shuffle
30 L/min (8 USgpm) • 270 bar (4000 psi)

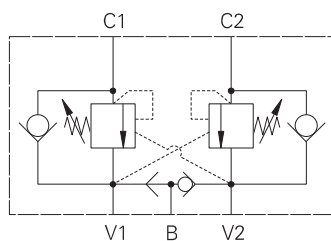

Operation

The check section allows free flow into the actuator then holds and locks the load against movement. The pilot assisted relief valve section will give controlled movement when pilot pressure is applied. The relief section is normally set to open at a pressure at least 1.3 times the maximum load induced pressure but the pressure required to open the valve and allow movement

depends on the pilot ratio of the valve. For optimization of load control and energy usage, a choice of pilot ratios is available.

The pressure required to open the valve and start actuator movement can be calculated as follows:

$$\text{Pilot Pressure} = \frac{(\text{Relief Setting}) - (\text{Load Pressure})}{\text{Pilot Ratio}}$$

Features

These valves have the excellent load control and safety features of the dual overcenter valve with the addition of a port for a brake release line. Smooth, safe performance.

Pilot ratio

2.5:1 Best suited for extremely unstable applications such as long booms or flexible frameworks.

5:1 (standard) Best suited for applications where load varies and machine structure can induce instability.

10:1 Best suited for applications where the load remains relatively constant.

Description

Overcenter Valves give static and dynamic control of loads by regulating the flow into and out of hydraulic actuators. When installed close to or within an actuator, the overcenter valve will stop runaway in the event of hose burst and if open centre directional control valves are used, will allow thermal expansion relief of the hydraulic fluid.

These dual overcenter valves also contain a brake release shuttle valve which ensures that pressure is applied to a brake release circuit regardless of whether pressure is applied to ports V1 or V2. These multifunction valves are normally used for the static and dynamic control of systems using motors or semi-rotary actuators.

Performance data

Ratings and specifications

Figures based on: Oil Temp = 40°C Viscosity = 32 cSt (150 SUS)

Rated flow	30 L/min (8 USgpm)
Max relief pressure	350 bar (5000 psi)
Max load induced pressure	270 bar (4000 psi)
Cartridge material	Working parts hardened and ground steel. External surfaces electroless nickel plated.
Standard housing material	Steel
Mounting position	Line Mounted
Weight	2.20 kg (4.84 lbs)
Seal kit	SK816 (Nitrile) SK816V (Viton®)
Filtration	BS5540/4 Class 18/13 (25 micron nominal)
Temperature range	-30° to +90°C (-22° to +194°F)
Internal leakage	0.3 milliliters/min nominal (5 dpm)
Nominal viscosity range	5 to 500 cSt

Viton is a registered trademark of E.I. DuPont.

Pressure drop

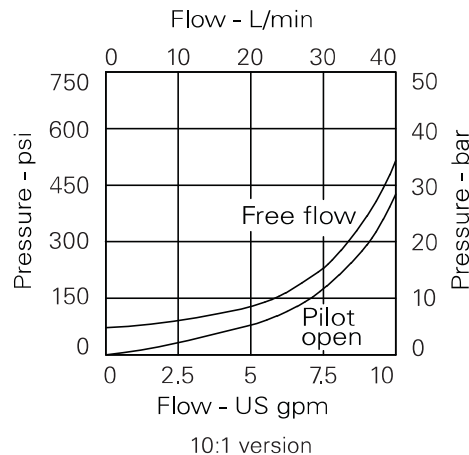
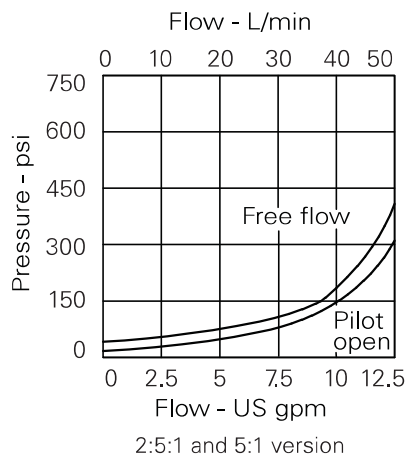

Where measurements are critical request certified drawings. We reserve the right to change specifications without notice.

ICEESH35 - Dual overcenter valve

Pilot assisted relief with brake shuffle
30 L/min (8 USgpm) • 270 bar (4000 psi)

Model code

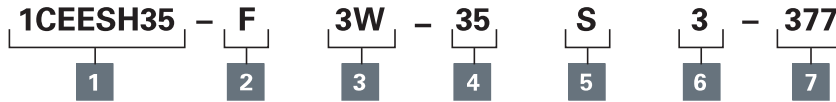

1 Basic code

1CEESH35 - Cartridge and Body

2 Adjustment

F - Screw adjustment

N - Fixed - State pressure setting required

For fixed versions add setting in 10 bar increments to end of part number. Subject to a ±10% tolerance.

3 Port size

Code	Port size	Housing number - sub assembly
3W	3/4" BSP Valve & Cyl Port 1/4" BSP Brake Port	BXP15939-3W-S-377

4 Pressure range @ 4.8 L/min

Note: Code based on pressure in bar.

35 - (2.5:1 and 5:1) 100-350 bar.
Std setting 210 bar
(10:1) 120-350 bar.

Std setting made at 4.8 L/min

5 Seal material

S - Nitrile (For use with most industrial hydraulic oils)

SV - Viton (For high temperature and most special fluid applications)

6 Pilot ratio

2 - 2.5:1

5 - 5:1 (Standard)

10 - 10:1

7 Body material

377 - Steel

Dimensions

mm (inch)

Complete valve

3/8" Ports

Basic Code

1CEESH35

Internally Cross Piloted

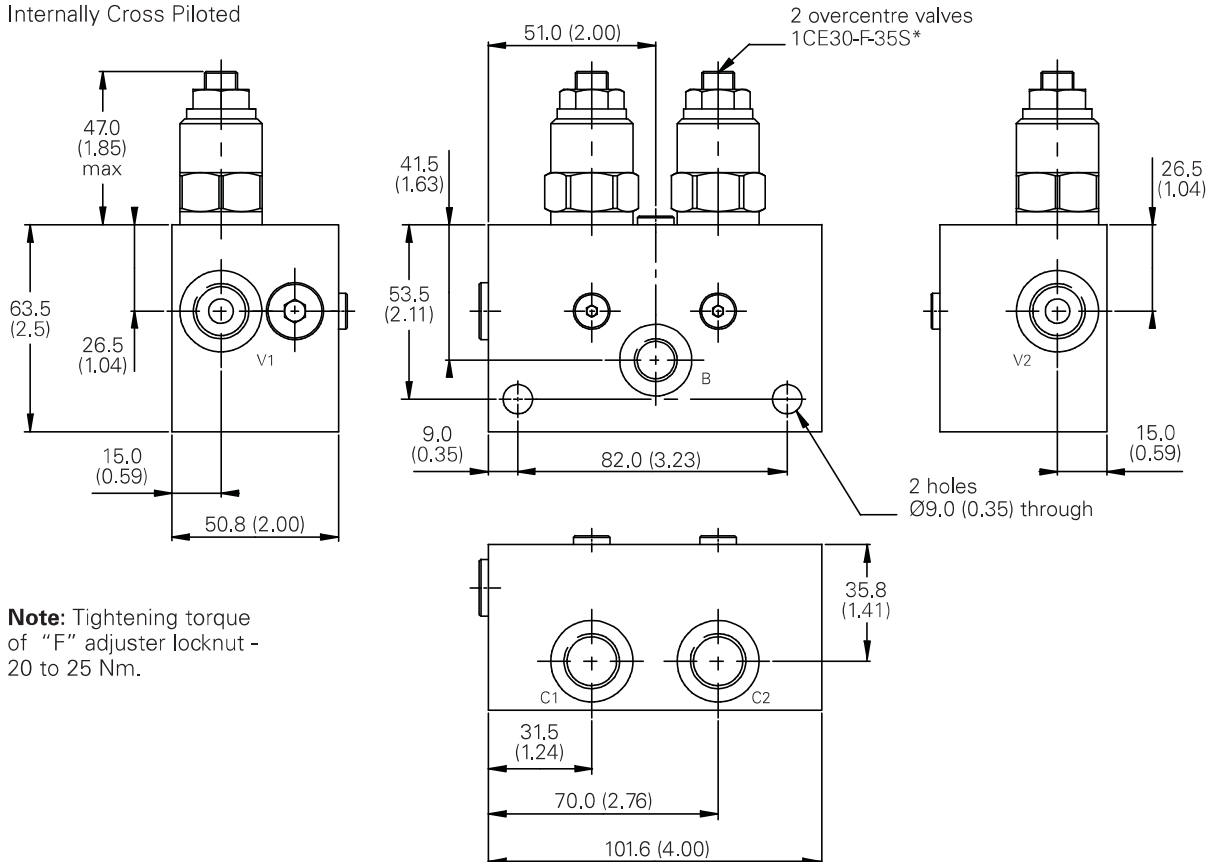

Note: Tightening torque of "F" adjuster locknut - 20 to 25 Nm.

Where measurements are critical request certified drawings. We reserve the right to change specifications without notice.