

ICEL30 - Overcenter valve

Counterbalance pilot assisted relief with check
30 L/min (8 USgpm) • 380 bar (5510 psi)

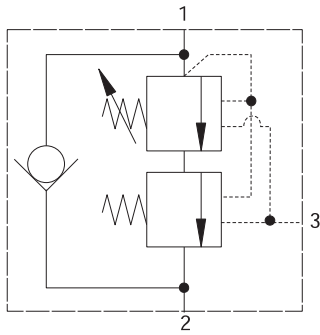

Operation

The check section allows free flow and then locks the load against movement. The pilot assisted relief valve section will give controlled movement when pilot pressure is applied, maintaining a counterbalance pressure to prevent initial

pressure loss and therefore instability. The total pressure setting will normally be set at 1.3 times the load induced pressure. The counterbalance pressure reduces as the pilot pressure increases.

Features

Cartridge is economical and fits simple cavity. Allows quick, easy field service - reduces down time. Interchangeable with pilot check valve of a similar size.

Pilot ratio

Primary 4.3:1

Secondary 0.4:1

Sectional view

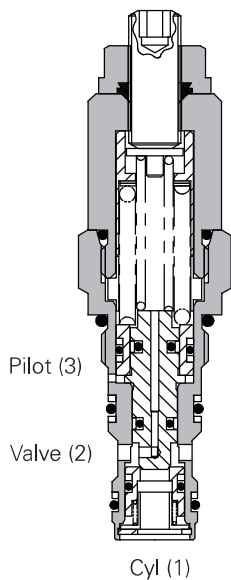

Performance data

Ratings and specifications

Performance data is typical with fluid at 32 cST (150 SUS)

Rated flow	30 L/min (8 USgpm)
Max setting	380 bar (5510 psi)
Internal leakage	0.3 ml/min (5 dpm)
Temperature range	-30° to +90°C (-22° to +194°F)
Cavity	A6610 (see Section M)
Torque cartridge into cavity	45 Nm (33 lbs ft)
Mounting position	Unrestricted
Filtration	BS5540/4 Class 18/13 (25 micron nominal)
Nominal viscosity range	5 to 500 cSt
Cartridge material	Working parts hardened and ground steel. External surfaces zinc plated.
Standard housing materials	Aluminium up to 210 bar. Add suffix "377" for steel option.
Weight	0.15 kg (0.33 lbs)
Seal kit	SK395 (Nitrile) SK395V (Viton®)

Viton is a registered trademark of E.I. DuPont.

Description

The ICEL overcenter valve performs all duties of a regular overcenter but maintains a counterbalance pressure to provide dampening of cylinders when there is a rapid loss in stored pressure. This counterbalance pressure reduces as the pilot pressure increases. Typical applications include extension cylinders on telescopic handlers where it is important to have a smooth operation when retracting from full extension.

Pressure drop

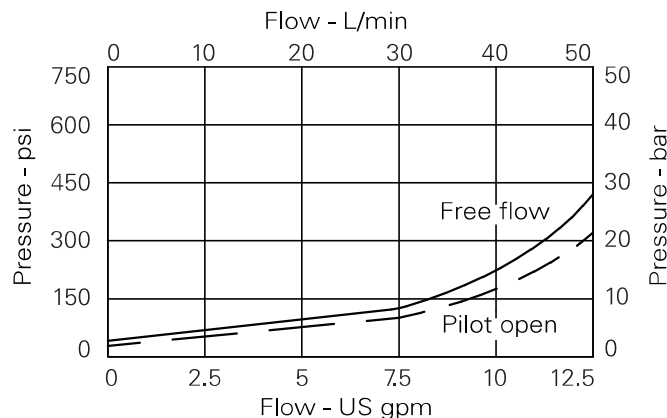

Note: This valve has been designed to eliminate instability from flexible boom applications or where the load induced pressure varies greatly. To get the best results, the settings should be adjusted for each application and then factory set for production quantities. Please contact our Technical Department for more information.

ICEL30 - Overcenter valve

Counterbalance pilot assisted relief with check
30 L/min (8 USgpm) • 380 bar (5510 psi)

Model code

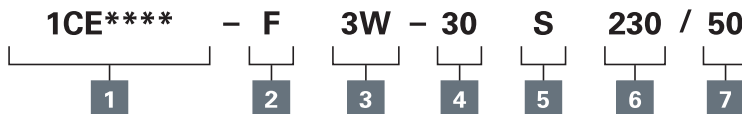

1 Function

- 1CEL30 - Cartridge only
- 1CEL35 - Cartridge and body
- 1CEEL34 - Cartridges and dual body

2 Adjustment means/ counterbalance setting

F - Screw adjustment
For fixed versions add setting in 10 bar increments to end of part number. Subject to a ±10% tolerance.

Dimensions

mm (inch)

Cartridge only

Basic Code
1CEL30

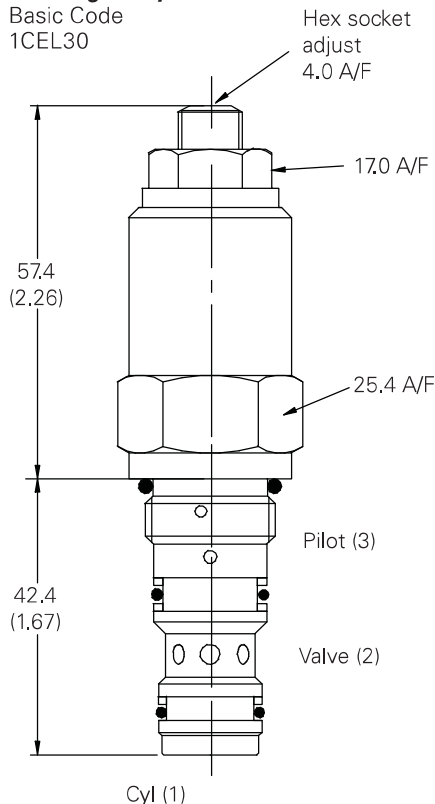

Note: Tightening torque of "F" adjuster locknut= 20-25 Nm.

3 Port size

Code	Port size	Housing number - body only			
		Aluminium single	Steel single	Aluminium dual	Steel dual
3W	3/8" BSP valve & cylinder port, 1/4" BSP pilot port	B6743	B12823	B6836	B13803
6T	3/8" SAE valve & cylinder port, 1/4" SAE pilot port	B10536	B10805		
8T	1/2" SAE valve & cylinder port, 1/4" SAE pilot port	B7884	B11811	B30237	B11812

4 Pressure range bar @ 4.8 L/min

Note: Code based on pressure in bar.
20 - 170-300 bar.
Std setting 220 bar
30 - 240-370 bar.
Std setting 280 bar
40 -270-380 bar.
Std setting 350 bar
Std setting made at 4.8 L/min

5 Seals

S - Nitrile
SV - Viton

6 High pressure setting bar

10 bar increments
150 to 310 bar
(2175 to 5000 psi)

7 Counterbalance setting bar

10 bar increments
20 to 120 bar (300 to 1740 psi)

Single valve

3/8", 1/2" Ports
Basic Code
1CEL35

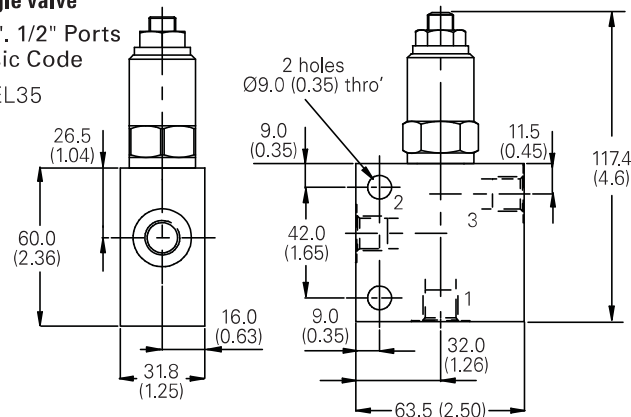

Dual valve

3/8", 1/2" Ports
Basic Code 1CEEL34
(Internally Cross Piloted)

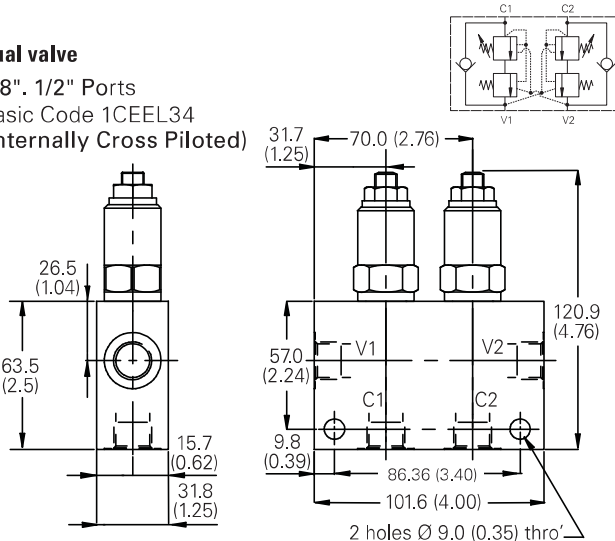

Where measurements are critical request certified drawings. We reserve the right to change specifications without notice.