

1CER140 - Overcenter valve

Part balanced, pilot assisted relief with check
140 L/min (37 USgpm) • 340 bar (4930 psi)

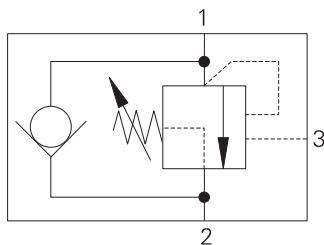

Operation

The check section allows free flow into the actuator then holds and locks the load against movement. The pilot assisted relief valve section will give controlled movement when pilot pressure is applied. The relief section is normally set to open at a pressure at least 1.3 times the maximum load induced pressure but the pressure required to open the valve and allow movement

depends on the pilot ratio of the valve. For optimization of load control and energy usage, a choice of pilot ratios is available.

The pressure required to open the valve and start actuator movement can be calculated as follows:

$$\text{Pilot Pressure} = \frac{(\text{Relief Setting}) - (\text{Load Pressure})}{\text{Pilot Ratio}}$$

Features

Cartridge is economical and fits simple cavity. Allows quick, easy field service - reduces down time. Interchangeable with pilot check valve of a similar size.

Pilot ratio

4:1 Best suited for applications where load varies and machine structure can induce instability.

6:1 Best suited for applications where the load remains relatively constant.

Sectional view

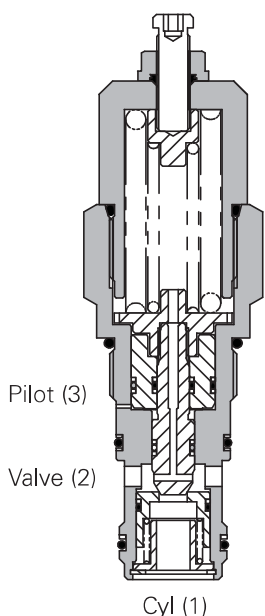

Performance data

Ratings and specifications

Figures based on: Oil Temp = 40°C Viscosity = 32 cSt (150 SUS)

Rated flow	140 L/min (37 USgpm)
Max relief setting	420 bar (6090 psi)
Max load induced pressure	340 bar (4930 psi)
Cartridge material	Working parts hardened and ground steel. External surfaces zinc plated.
Standard housing material	Aluminum (up to 210 bar). Add suffix "377" for steel option.
Mounting position	Unrestricted
Cavity number	A20081
Torque cartridge into cavity	150 Nm (110 lbs ft)
Weight	1CER140 1.2 kg (2.6 lbs) 1CER145 (aluminium) 2.2 kg (4.8 lbs) 1CER145 (steel) 4.0 kg (8.8 lbs) 1CEER145 (aluminium) 2.9 kg (6.4 lbs) 1CEER145 (steel) 6.0 kg (13.2 lbs)
Seal kit number	SK1108 Nitrile SK1108V (Viton®)
Recommended filtration level	BS5540/4 Class 18/13 (25 micron nominal)
Operating temperature	-30° to +90°C (-22° to +194°F)
Leakage	0.3 milliliters/min nominal (5 dpm)
Nominal viscosity range	5 to 500 cSt

Viton is a registered trademark of E.I. DuPont.

Pressure drop

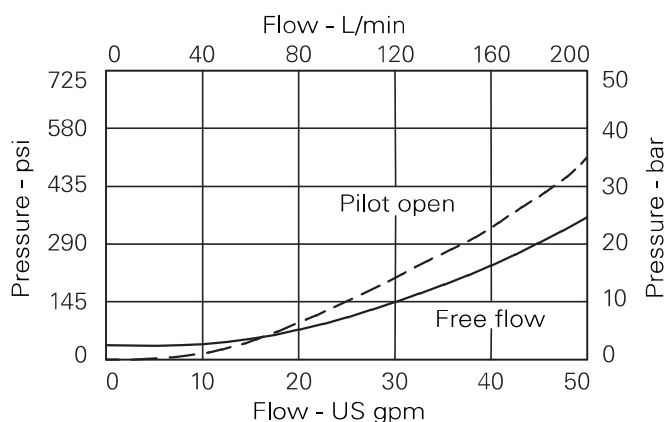

Description

The 1CER series overcenter valve performs all duties of a regular overcenter but is able to relieve and stay open irrespective of downstream pressure. This enables the valve to operate when used with a closed center directional valve which has service line reliefs. The poppet is pressure balanced, preventing relief setting increase due to back pressure.

Where measurements are critical request certified drawings. We reserve the right to change specifications without notice.

1CER140 - Overcenter valve

Part balanced, pilot assisted relief with check
140 L/min (37 USgpm) • 340 bar (4930 psi)

Model code

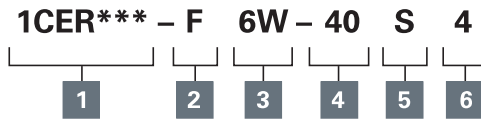

1 Function

- 1CER140** - Cartridge Only
- 1CER145** - Cartridge and Body
- 1CEER145** - Cartridges and Body

2 Adjustment means

F - Screw Adjustment

3 Port sizes

Code	Port size	Housing number - body only			
		Aluminium single	Steel single	Aluminium dual	Steel Dual
6W	3/4" BSP Valve & Cyl Port. 1/4" BSP Pilot Port	B20105	B20106		
8W	1" BSP Valve & Cyl Port. 1/4" BSP Pilot Port	B20107	B20108	C20285	C20287
12T	3/4" SAE Valve & Cyl Port. 1/4" SAE Pilot Port	B11952	B11953		
16T	1" SAE Valve & Cyl Port. 1/4" SAE Pilot Port	B11946	B11947	C30105	C30106

4 Pressure range @ 4.8 l/min

Note: Code based on pressure in bar.

- 20** - 140-250 bar.
Std setting 190 bar
- 30** - 220-330 bar.
Std setting 270 bar
- 40** - 310-420 bar.
Std setting 370 bar
Std setting made at 4.8 L/min

5 Seals

S - Nitrile (For use with most industrial hydraulic oils)

SV - Viton (For high temperature and most special fluid applications)

6 Pilot ratio

4 - 4:1

6 - 6:1

Other ratios available upon request

Dimensions

mm (inch)

Cartridge only

Basic Code
1CER140

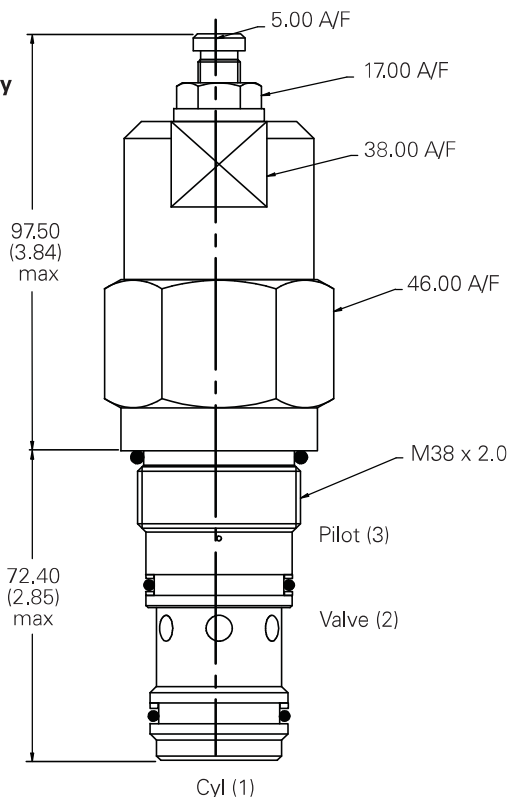

Note: For applications above 210 bar - please consult our technical department or use the steel body option

Note: Tightening torque of "F" adjuster locknut - 20 to 25 Nm.

Single valve

3/4", 1" Ports
Basic Code
1CER145

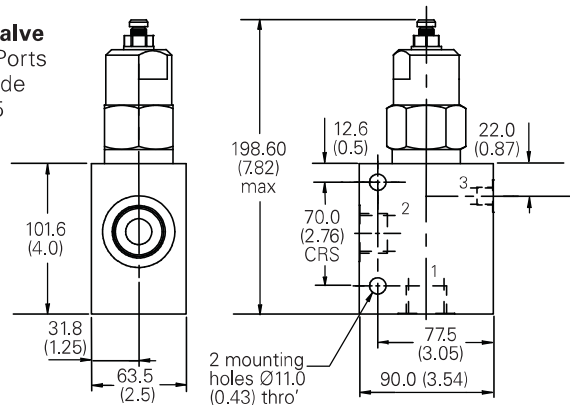

Dual valve

1" Ports
Basic code 1CEER145
Internally Cross Piloted

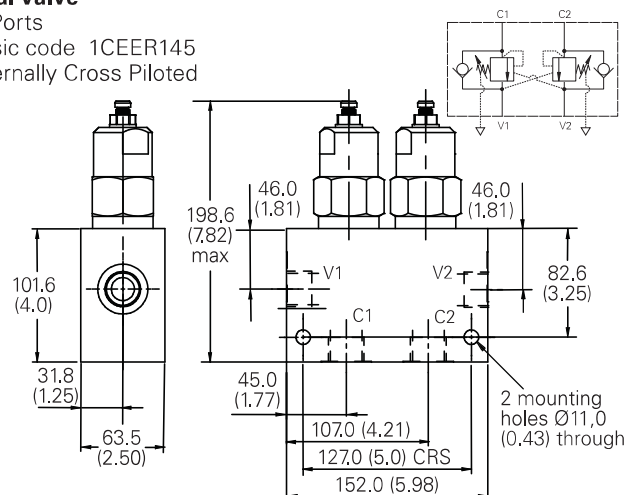

Where measurements are critical request certified drawings. We reserve the right to change specifications without notice.