

3CP2 - Series check valve

Check, manually operated
 5.5-15 L/min (1.5-4 USgpm) • 210 bar (3000 psi)

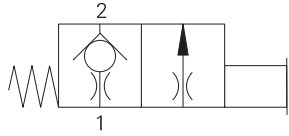

Sectional view

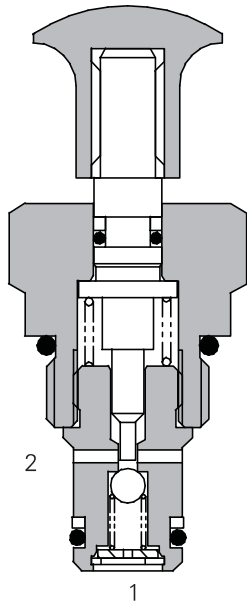

Operation

The poppet seals flow from ports 1 to 2, depressing the hand knob lifts the poppet from its seat permitting flow the flow rate is determined by the size of the orifice and the pressure in the system, various orifice sizes are available.

Flow from port 2 to 1 should be avoided - if required please consult our technical department.

Features

Cartridge design with machined seats and precision ground balls gives excellent flow reseal characteristics.

Performance data

Ratings and specifications

Performance data is typical with fluid at 21,8 cST (105 SUS) and 49°C (120°F)

Max pressure	210 bar (3000 psi)
Rated flow	.9 mm orifice 5.5 L/min (1.4 US gpm), 1.5 mm orifice 15 L/min (4 US gpm)
Internal leakage	.3 ml/min nominal (5 dpm)
Temperature range	-30° to 90°C (-22° to 194°F)
Cavity	A879 (see Section M)
Torque cartridge into cavity	45 Nm (33 lbs ft)
Mounting position	Unrestricted
Filtration	BS5540/4 Class 18/13 (25 micron or better)
Nominal viscosity range	5 to 500 cSt
Cartridge material	All steel construction. External parts electroless zinc plated.
Standard housing materials	Aluminum
Weight	.05 kg (.11 lbs)
Seal kit	SK187 (Nitrile) SK187V (Viton®)

Viton is a registered trademark of E.I. DuPont

Pressure drop

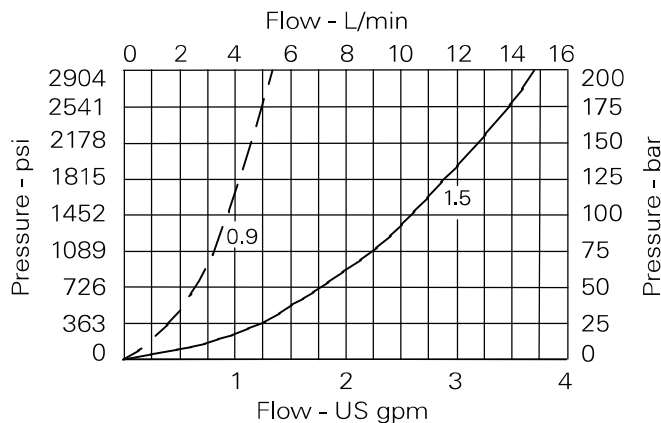

Description

These cartridges permit a small regulated flow to pass when the hand knob is depressed. A typical application would be on an access platform to lower the boom in the event of a power failure.

Where measurements are critical request certified drawings. We reserve the right to change specifications without notice.

3CP2 - Series check valve

Check, manually operated
5.5-15 L/min (1.5-4 USgpm) • 210 bar (3000 psi)

Model code

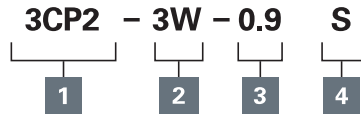

1 Function

3CP2 - Cartridge only
3CP25 - Cartridge and body

2 Port size

Code	Port size	Housing number	
		Aluminum	Steel
0	Cartridge only		
2W	1/4" BSP	A1485	
3W	3/8" BSP	A1043	A18175
6T	3/8" SAE	A15676	A14843

See section J for housing details.

3 Orifice size

0.9 - 0.9 mm
1.5 - 1.5 mm

4 Seals

S - Nitrile
SV - Viton

Dimensions

mm (inch)

Cartridge only

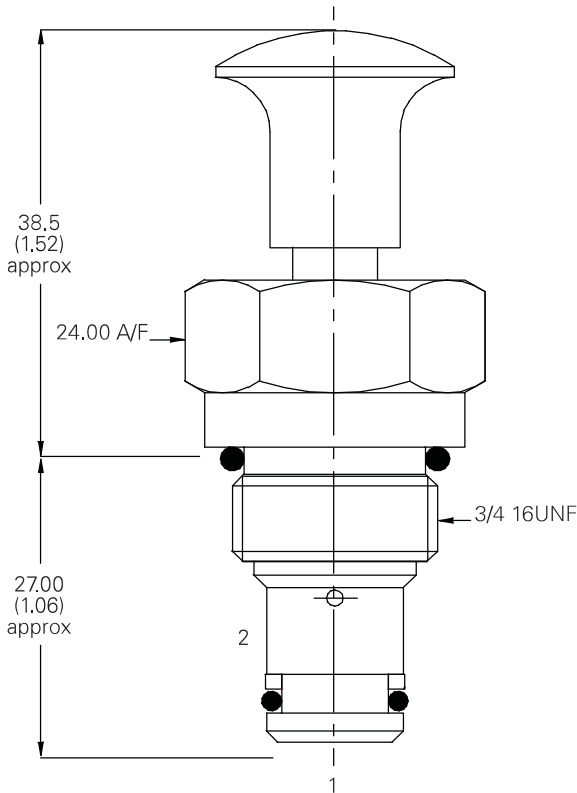

Installation drawing

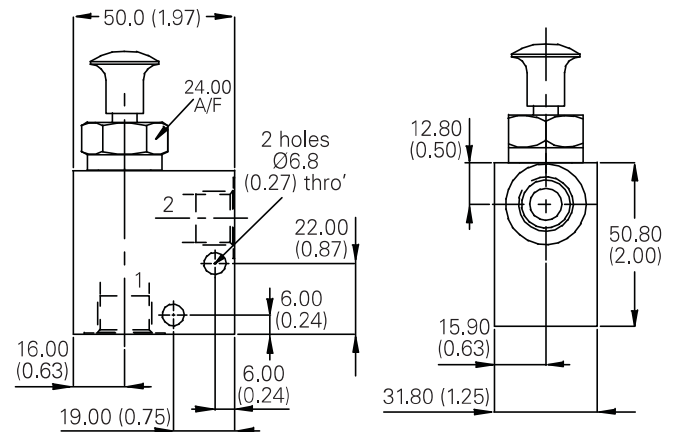

Where measurements are critical request certified drawings. We reserve the right to change specifications without notice.