

ICEOMS95/ICEEOMS95 - Motor mounted valves

OMS Mounting pattern single and dual overcenter valves

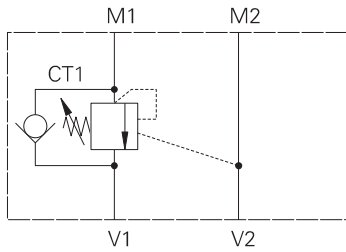

1CEOMS95-1

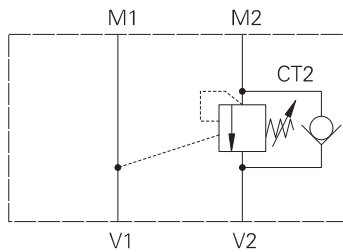

1CEOMS95-2

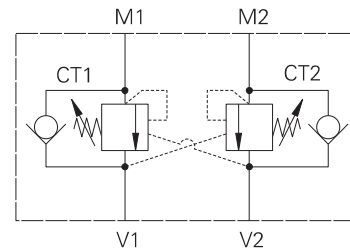

1CEEOMS95

Description

Overcenter valves give static and dynamic control of loads by regulating the flow into and out of hydraulic actuators. When installed close to or within an actuator, the overcenter valve will stop runaway in the event of hose burst and if open center directional control valves are used, will allow thermal expansion relief of the hydraulic fluid.

The overcenter cartridge is ideal for mounting directly into a cavity machined in the body of the cylinder, motor or rotary actuator. The cartridge can also be mounted directly to the ports via a specifically machined body as part of a Hydraulic Integrated Circuit or single unit, or contained within one of our standard line bodies.

Single overcenter valves are normally used when the load is unidirectional, for example an aerial platform or crane and dual overcenter valves are used for controlling loads in both directional for motor applications or for cylinders going over center.

Operation

The check section allows free flow into the actuator then holds and locks the load against movement. The pilot assisted relief valve section will give controlled movement when pilot pressure is applied. The relief section is normally set to open at a pressure at least 1.3 times the maximum load induced pressure but the pressure required to open the valve and allow movement depends on the pilot ratio of the valve. For optimization of load control and energy usage, a choice of pilot ratios is available.

Performance data

Ratings and specifications

Figures based on: Oil Temp = 40°C Viscosity = 32 cSt (150 SUS)

Rated flow	90 L/min (23 USgpm)
Max setting	Max load induced Pressure: 270 bar (4000 psi) Relief setting: 350 bar (5000 psi)
Cartridge material	Working parts hardened & ground steel External surface zinc plated
Body material	Standard aluminium (up to 210 bar*) Add suffix '377' for steel option
Mounting position	Unrestricted
Cavity Number	A12336 (See section M)
Torque cartridge into cavity	60 Nm (44 lbs ft)
Weight (inc cartridges)	1CEOMS95 2.16 kg (4.75 lbs) 1CEEOMS95 2.26 kg (4.97 lbs)
Seal kit number	1CEOMS95 SK1282 (Nitrile) SK1282V (Viton) 1CEEOMS95 SK795 (Nitrile) SK795V (Viton)
Recommended filtration level	BS5540/4 Class 18/13 (25 micron nominal)
Operating Temp	-30°C to +90°C (-22° to 194°F)
Leakage	0.3 milliL/min nominal (5 dpm)
Nominal viscosity range	5 to 500 cSt

Pilot Ratios

- 4:1 Best suited for applications where load varies and machine structure can induce instability
- 8:1 Best suited for applications where the load remains relatively constant.
- Other ratios available upon request

Where measurements are critical request certified drawings. We reserve the right to change specifications without notice.

ICEOMS95/ICEEOMS95 - Motor mounted valves

OMS Mounting pattern single and dual overcenter valves

Pressure drop

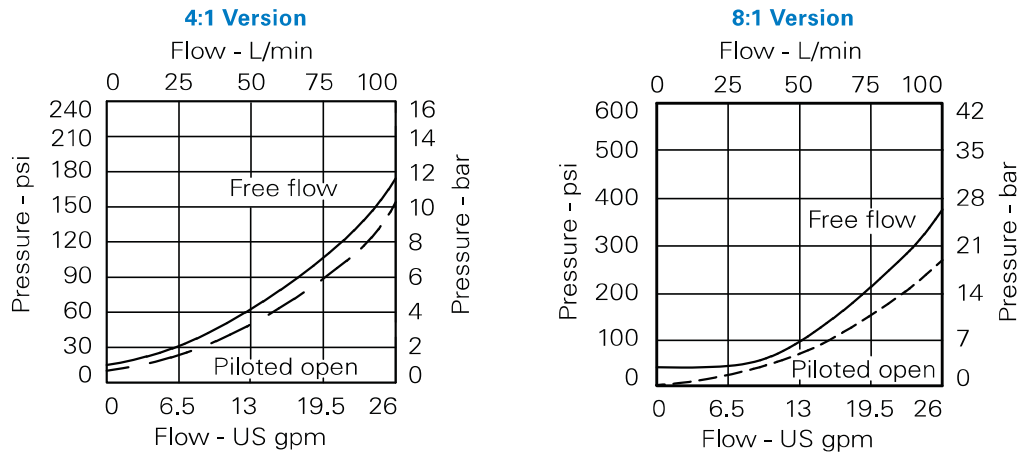

Model code

1CE*OMS95-* - F 4W - 35 S 4 BK

1 2 3 4 5 6 7

1 Basic code

1CEEOMS95 - Double Cartridge and Body
1CEOMS95-1 - Single overcenter in line V1-M1
1CEOMS95-2 - Single overcenter in line V2-M2

2 Adjustment means

F - Screw Adjustment

Dimensions

mm (inch)

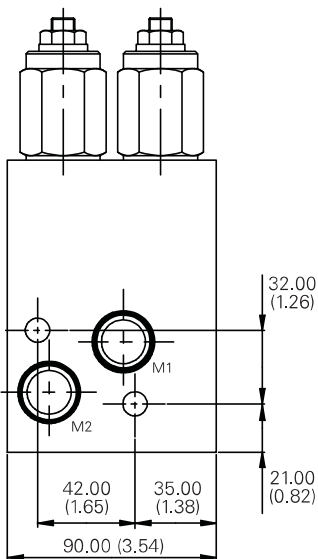
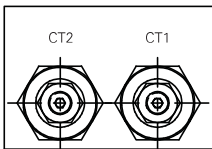

3 Port size

Code	V1 & V2	Brake	Housing number
4W	1/2" BSPP	1/4" BSPP	BXP24055-4W-S

4 Pressure range

Note: Code based on pressure in bar.

- 20** - 70-225 bar. Std setting 100 bar
- 35** - 200-350 bar. Std setting 210 bar

Std setting made at 4.8 L/min
 * Cartridges must not be adjusted above the safe working pressure of the motor

Complete Valve 1/2" Ports Basic Code: 1CEEOMS95

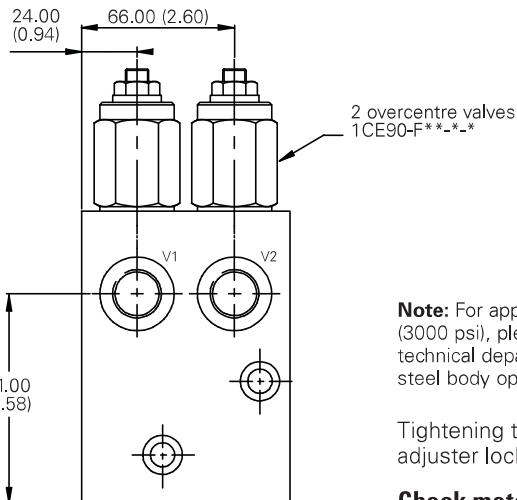
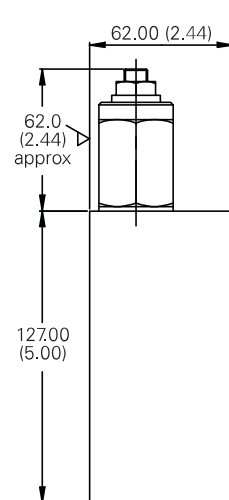

6 Pilot ratio

4	-	4:1
8	-	8:1

7 Mounting

BK - Bolt Kit

Cavity plug part number

Nitrile
AXP14434-02-N

Viton
AXP14434-02-V

Note: For applications over 210 bar (3000 psi), please consult our technical department or use the steel body option.

Tightening torque of "F" adjuster locknut - 20 to 25 Nm

Check motor mounting compatibility before specifying.

Where measurements are critical request certified drawings. We reserve the right to change specifications without notice.