

1SB10 - Brake sequence valve

Brake sequence directional valve
 10 L/min (2.5 USgpm) • 350 bar (5000 psi)

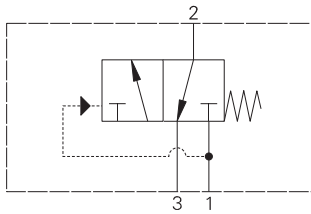

Operation

When the pressure in the inlet line is below the switching pressure (15 bar), the outlet will be connected to the tank, the spool being held in place by the spring force.

When the pressure in the inlet line exceeds the switching pressure, the spool will slide back, opening inlet to outlet.

Features

Cartridge design enabling speedy servicing when mounted in a body or in a composite manifold.

Sectional view

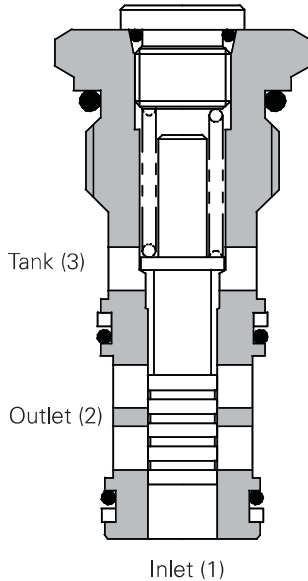

Performance data

Ratings and specifications

Performance data is typical with fluid at 21,8 cST (105 SUS) and 49°C (120°F)

Max working pressure	350 bar (5000 psi)
Rated flow	10 L/min (2.5 US gpm)
Internal leakage	50 ml/min nominal
Temperature range	-30° to 90°C (22° to 194°F)
Cavity	A893 (see Section M)
Torque cartridge into cavity	60 Nm (44 lbs ft)
Mounting position	Unrestricted
Filtration	BS5540/4 Class 18/ 13 (25 micron or better)
Nominal viscosity range	5 to 500 cSt
Cartridge material	All working parts hardened and ground steel. External surfaces zinc plated.
Standard housing materials	Aluminum and Steel
Weight	1SB10 .12 kg (.26 lbs), 1SB15 1.0 kg (2.2 lbs)
Seal kit	SK182 (Nitrile) SK182V (Viton®)

Viton is a registered trademark of E.I. DuPont

Description

This valve provides a bias so that a predetermined pressure (15 bar) has to be reached before the valve will switch. In a typical brake circuit the brake will be held on until system pressure reaches the bias pressure. Once this pressure has been reached the valve will switch and supply pressure to the brake to hold it off. If the pressure then falls below the bias pressure the valve will again switch, applying the brake in a controlled manner.

Pressure drop

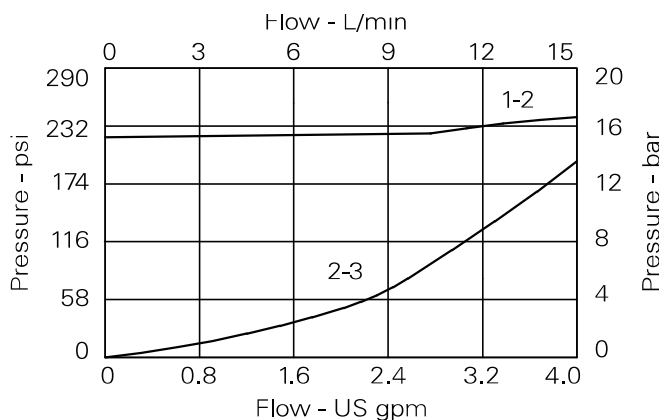

Where measurements are critical request certified drawings. We reserve the right to change specifications without notice.

1SB10 - Brake sequence valve

Brake sequence directional valve
10 L/min (2.5 USgpm) • 350 bar (5000 psi)

Model code

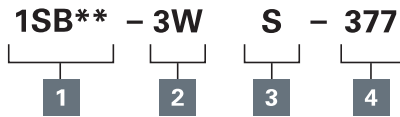

1 Function
1SB10 - Cartridge only

2 Port size

Code	Port size	Housing number	
		Aluminum single	Steel
0	Cartridge only		
2W	1/4" BSP		A1882
3W	3/8" BSP		A1883
6T	3/8" SAE	A10715	A7371

3 Seals

S - Nitrile
SV - Viton

4 Body material

377 - Steel
(Omit for aluminum (up to 210 bar)).

Dimensions

mm (inch)

Cartridge only

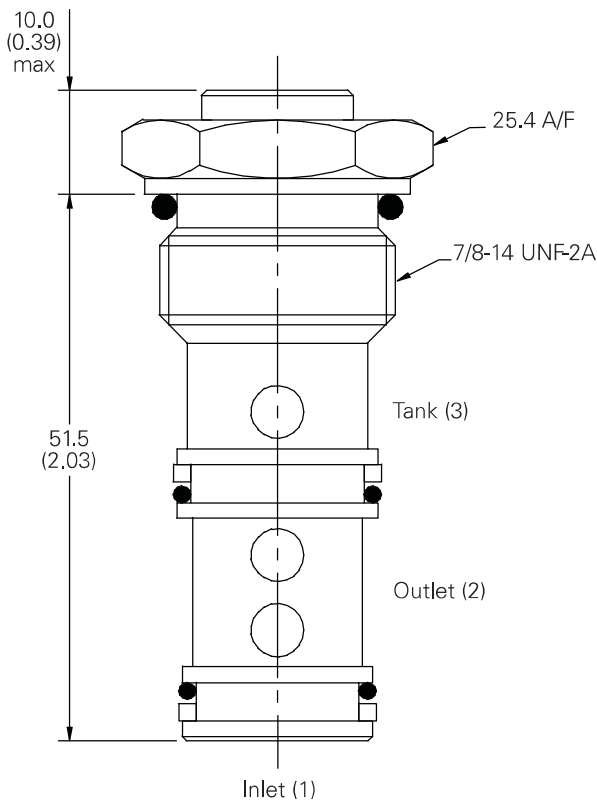

Installation drawing

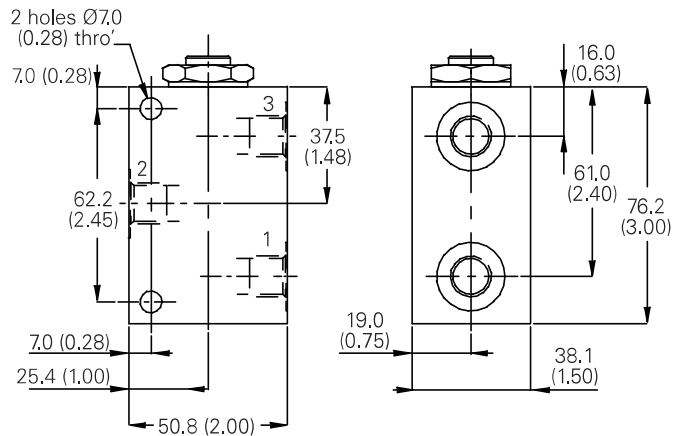

Where measurements are critical request certified drawings. We reserve the right to change specifications without notice.