

SECTION E

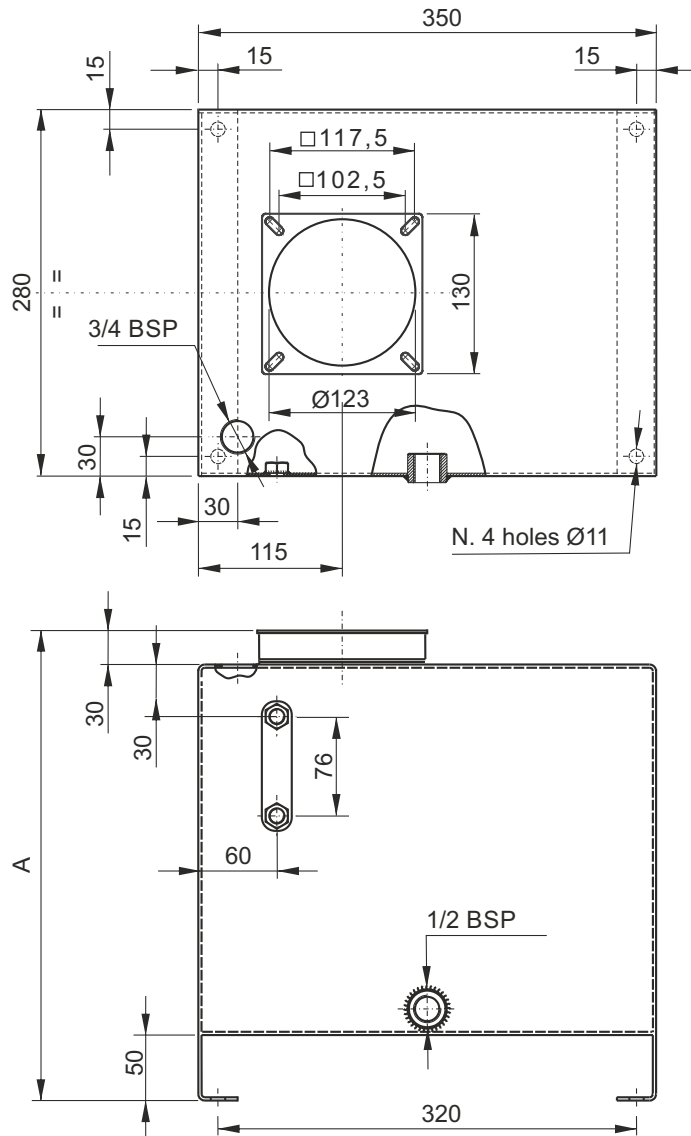

SQUARE WELDED STEEL TANKS E SERIES



Description	Spare part code	Assembly code	A (mm)	Weight	Actual filling volume (lt)	
					Horizontal	Vertical
20 l square vertical mounting	E60303015	20EV	293	6,50 Kg	-	20,8
30 l square vertical mounting	E60303048	30EV	423	8,50 Kg	-	33,5

All dimensions are in mm

Material	Fe P04-EN10130 steel sheet 2,5mm thickness on top and side, 1,5mm thickness front and rear
Fluid	Mineral based oil ISO/DIN 6743/4
Working temperature	-15 / +70°C

Notes: the piping kit, standard suction strainer, filler/breather, level gauge and drain plug are included when specifying the tank in PPC assembly code.

When ordering spare tanks, only the drain plug, filler/breather and level gauge are included.

On request special square welded tanks can be manufactured. An inquiry must be sent to our technical department with indication of quantities.