

INTEGRAL DC MOTORS Ø114

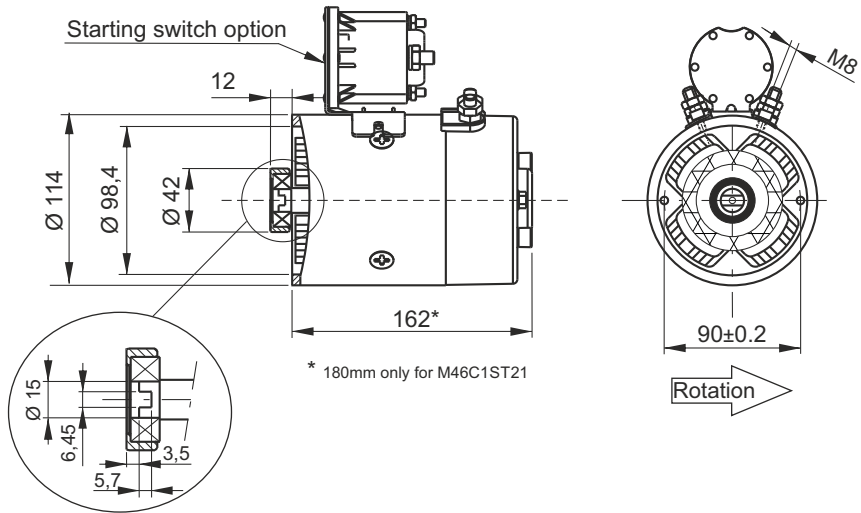

Compound wound
 Protection degree: IP54
 Insulation class: F
 Weight: 7,05 kg (without starting switch)



Code

Description	Assembly code	Spare part code	Nominal duty cycle	Nominal speed	Nominal current
1600W 12V DC + thermal protection	1,6 12DC_T	M46C1ST16	S2: 3 min S3: 10% ED	2800 rpm	210 A
2100W 12V DC + thermal protection	2,1 12DC_T	M46C1ST21	S2: 2,5 min S3: 10% ED	2400 rpm	300 A
2200W 24V DC + thermal protection	2,2 24DC_T	M46C2ST22	S2: 3,5 min S3: 15% ED	2400 rpm	130 A

Options & couplings

Description	Assembly code	Spare part
12V DC 150 Amp start switch + mounting kit	S150T 12DC 112	M47TC0001 + M47SK1121
24V DC 150 Amp start switch + mounting kit	S150T 24DC 112	M47TC0002 + M47SK1121
Plastic protection cover for Ø114 motors	MC	F16000001
Coupling for Ø114 motors and gr.0 pump	E36200005	
Coupling for Ø114 motors-Ø125DC motors and gr.1 pump	E36200001	
Remote wired control with 2 buttons and 3m cable	P0201 (single acting)	
Remote wired control with 4 buttons and 3m cable	P0202 (double acting)	

Notes: the starting switch mounting kit is provided when specifying the /S150 as motor option in PPC assembly code. When ordering spare starting switches, it must be ordered separately (code: M47SK1121).

The coupling is already included when specifying the motor in PPC assembly code. It is to be indicated only when ordering PPC with no motor but with coupling.

Coupling E36200005

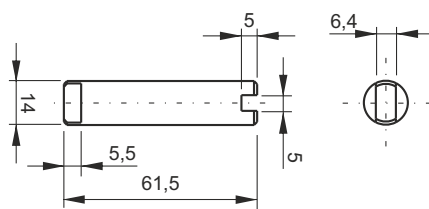

Weight: 0,068 kg

Coupling E36200001

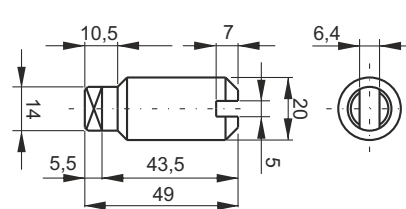

Weight: 0,094 kg