

4SK90 - Check valve

Pilot-to-open, poppet type
90 L/min (24 USgpm) • 350 Bar (5000 psi)

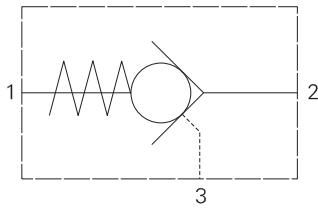

Operation

Pressure on the valve port 2 causes the poppet to lift against the spring force, allowing the flow to the cylinder port 1. Reverse flow is prevented by the poppet reseating. Pressure applied

to the pilot port 3 will overcome the cylinder port pressure and lift the poppet from its seat, allowing flow from the cylinder to valve port.

Features

Hardened and ground poppet gives excellent flow capability for valve size, positive sealing and long working life. Cartridge construction allows installation in actuators, manifold blocks and Hydraulic Integrated Circuits. Fits the same cavity as the overcenter valves of a similar size.

Sectional view

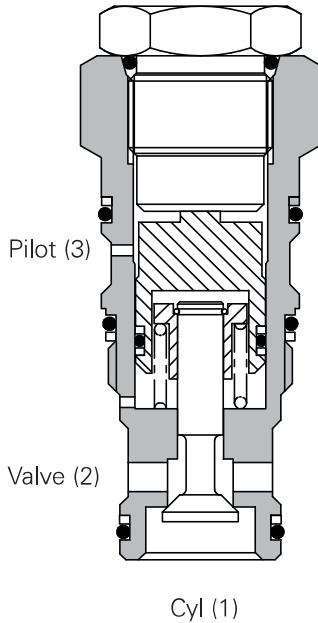

Performance data

Ratings and specifications

Figures based on oil temperature of 40° C and viscosity of 32 cSt (150 SUS)

Rated flow	90 L/min (24 USgpm)
Maximum pressure	350 bar (5000 psi)
Pilot ratio	4:1
Cartridge material	Working parts hardened and ground steel. Zinc plated body
Mounting position	Unrestricted
Cavity number	A20092-T2A
Torque cartridge into cavity	60 Nm (44 lbs. ft.)
Weight	0.39 kg (0.86 lbs.)
Seal kit number	SK1093 (Nitrile) SK1093V (Viton®)
Recommended Filtration level	BS5540/4 Class 18/13 (25 micron nominal)
Operating temperature	-30°C to +90°C (-22° to +194°F)
Leakage	0.3 ml/min nominal (5 dpm)
Nominal viscosity range	5 to 500 cSt

Viton is a registered trademark of E. I. DuPont

Description

Pilot check valves allow flow to pass in one direction, with a low pressure drop, then prevent reverse flow until pilot pressure is applied. There are many applications for this valve type, the most common being to lock and hold a cylinder, or another hydraulic actuator, in position.

These valves are ideally suited for fitting directly into a cylinder, giving economy of installation, direct control of cylinder movement and ease of servicing.

Pressure drop

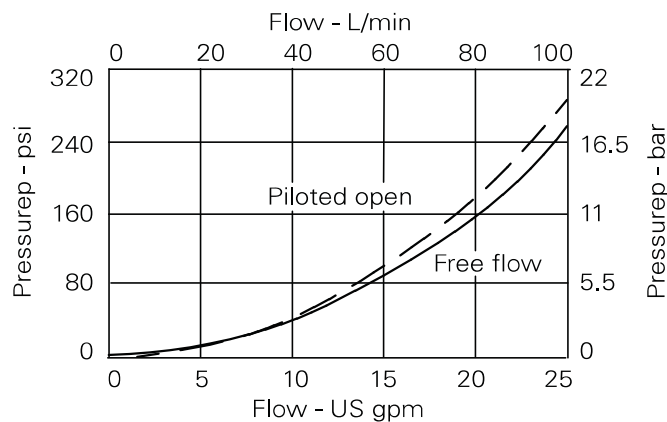

Where measurements are critical request certified drawings. We reserve the right to change specifications without notice.

4SK90 - Check valve

Pilot-to-open, poppet type
90 L/min (24 USgpm) • 350 Bar (5000 psi)

Model code

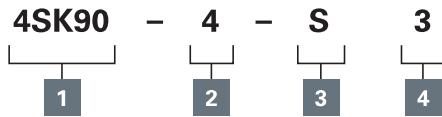

1 Basic code

4SK90 - Complete valve

2 Pilot ratio

4 - 4:1

3 Seals

S - Nitrile (for use with most industrial hydraulic oils)

SV - Viton (for high temperature & most special fluid applications)

4 Optional pilot seal

Omit if not required

Dimensions

mm (inch)

Cartridge only

Basic code
4SK90

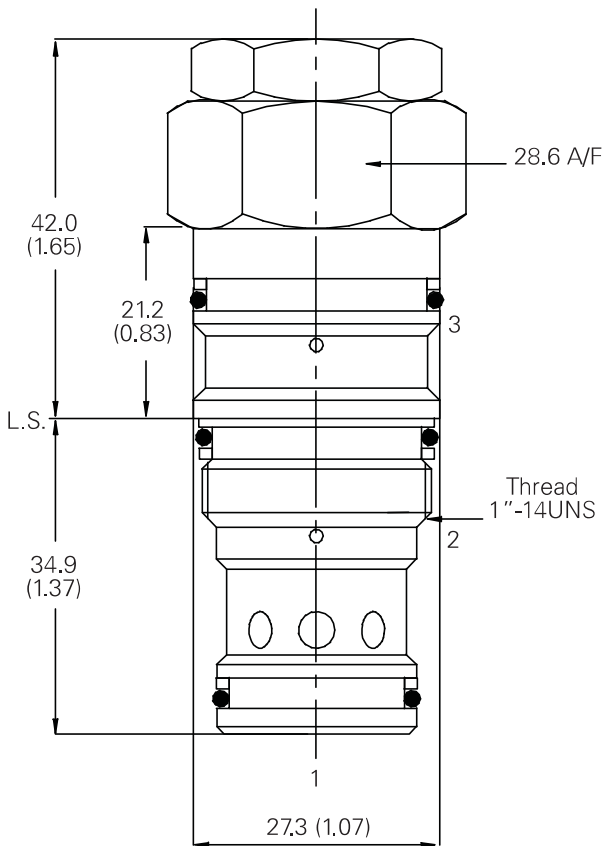

Cavity

Basic code A20092-T2A

Form drill TD-2A

Form reamer TR-2A

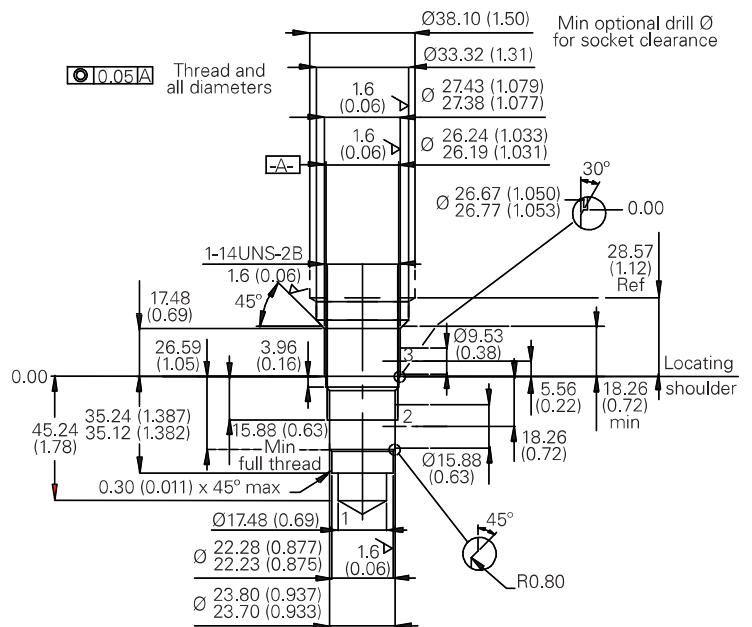

Note: For applications above 210 bar (3000 psi) please consult our technical department or use the steel body.

Where measurements are critical request certified drawings. We reserve the right to change specifications without notice.