

FDC1-16 - Flow divider/combiner

Pressure compensated, spool type
Up to 178 L/min (47 USgpm) • 210 bar (3000 psi)

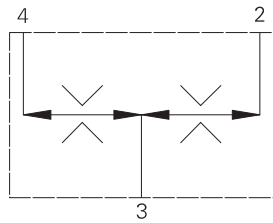

Operation

Inlet flow passes through the two matched orifices in the spools, through the spools and out of the radial holes in the sleeve. The matched orifices and the compensating springs ensure that the flow is divided equally, excess flow in either

direction causes the spool to move and close the radial holes in the sleeve until equilibrium is restored. In the reverse direction the spools close together and regulate the flow in through the radial ports.

Features

One valve synchronizes in both directions. Matched spools give high accuracy under load and pressure imbalance conditions. Cartridge construction gives versatility of application. A valve may be fitted into a line body, a custom designed Hydraulic Integrated Circuit or other hydraulic equipment.

Sectional view

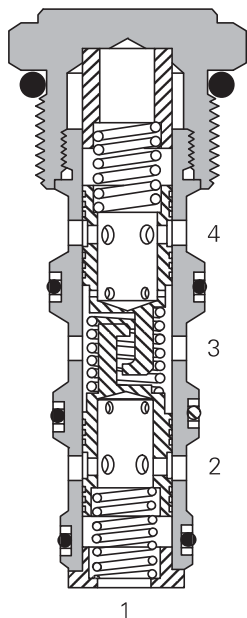

Performance data

Ratings and specifications

Performance data is typical with fluid at 21,8 cSt (105 SUS) and 49°C (120°F)

Typical application pressure (all ports)	210 bar (3000 psi)
Cartridge fatigue pressure (infinite life)	210 bar (3000 psi)
Rated inlet flow	See model code
Temperature range	-40° to 120° C (-40° to 248° F)
Cavity	C-16-4
Fluids	All general purpose hydraulic fluids such as MIL-H-5606, SAE 10, SAE 20, etc.
Filtration	Cleanliness code 18/16/13
Standard housing materials	Aluminum
Weight cartridge only	0,35 kg (0.78 lbs)
Seal Kits	889634 (Buna-N) 889638 (Viton®)

Viton is a registered trademark of E.I. DuPont

Description

This range of flow divider/combiner valves gives division of input flow into two equal parts and re-combination of flow in the reverse direction. Pressure compensation ensures that whether dividing or combining, equal flow is maintained over a wide range of pressure variation. A typical use of these valves is to divide a pump flow to operate two actuators (which may be under different load conditions and at different pressures) and to re-combine the return flows to synchronize actuator movement. Flow variation is within $\pm 10\%$ with the maximum variation of pressure and inlet flow and under normal conditions will be significantly less.

Pressure drop

Cartridge only

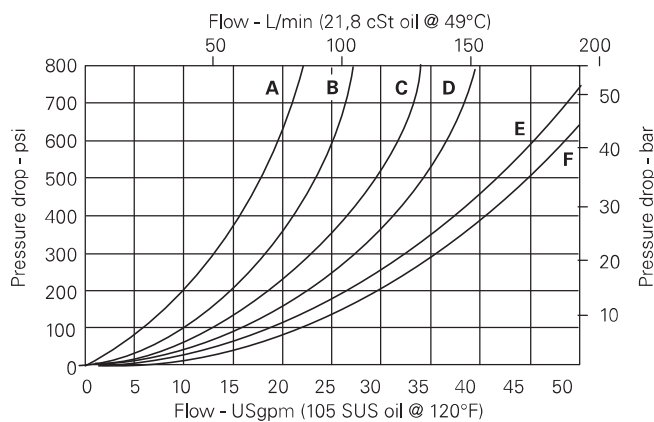

Flow division

(See model code position 5)

- A - 2* spool
- B - 3* spool
- C - 4* spool
- D - 5* spool
- E - 6* spool
- F - 8* spool

Where measurements are critical request certified drawings. We reserve the right to change specifications without notice.

FDC1-16 - Flow divider/combiner

Pressure compensated, spool type
Up to 178 L/min (47 USgpm) • 210 bar (3000 psi)

Model code

FDC1 - 16 (V) - * - ** - 00**

1 2 3 4 5 6

1 Function

FDC1 - Flow divider/combiner

2 Size

16 - 16 size

4 Port size

Code	Port size	Housing number
		Aluminium light duty
0	Cartridge only	
12T	SAE 12	566200
6B	3/4" BSPP	02-175468

See section J for housing details.

3 Seals

Blank - Buna-N
V - Viton®

5 Flow divisions (Ratios)

Code	Flow division %		Rated inlet flow	
	Port 4	Port 2	L/min	(USgpm)
22	50	50	045,6	(12)
28	20	80	114,0	(30)
33	50	50	068,0	(18)
36	33	67	098,0	(26)
43	57	43	079,0	(21)
44	50	50	090,0	(24)
46	40	60	114,0	(30)
55	50	50	114,0	(30)
62	75	25	090,0	(24)
63	67	33	098,0	(26)
64	60	40	114,0	(30)
66	50	50	132,0	(35)
82	80	20	114,0	(30)
84	67	33	132,0	(35)
88	50	50	178,0	(47)

Dimensions

mm (inch)

Torque cartridge in aluminum housing to 108–122 Nm (80–90 ft lbs)

Cartridge only

Basic code
FDC1-16

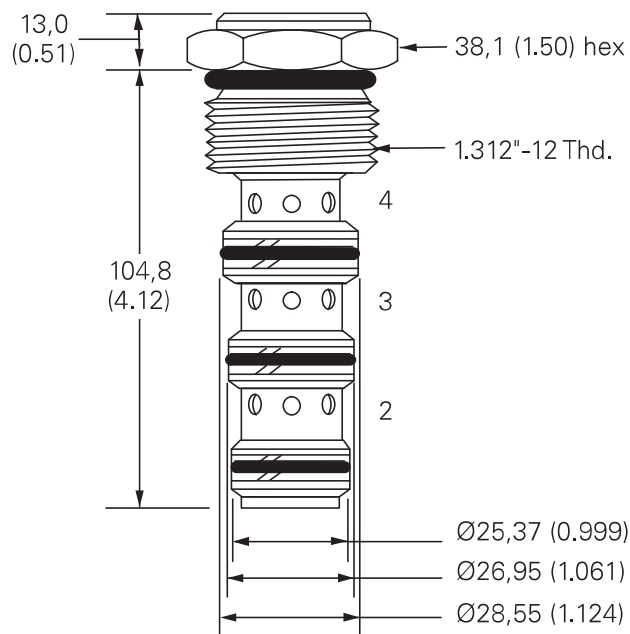

6 Special features

00 - None
(Only required if valve has special features, omitted if "00".)

Notes: Port 1, unused, blocked by blind cavity.
Minimum inlet flow should not be less than 1/4 of maximum inlet flow for a given code.

Where measurements are critical request certified drawings. We reserve the right to change specifications without notice.